

*Improving
mobility*

*Easing
congestion*

*Strengthening
our communities*

Central Corridor Light Rail Transit

Union Depot Station

Artists Andrea Myklebust and Stanton Sears developed this design for the Union Depot LRT Station based on public input received at the station art visioning session held in March, feedback received at the June public meeting and on research and interviews:

- A unique black granite wheel sculpture in a transportation theme located in the center of each station platform (side platform station)
- One bronze sculpture inspired by stacks of different wheels will be placed on a light column on each platform
- The two large panels on each platform will include a band of transportation inspired artwork
- A concrete palette complementing yet distinctly different from the Union Depot's color palette

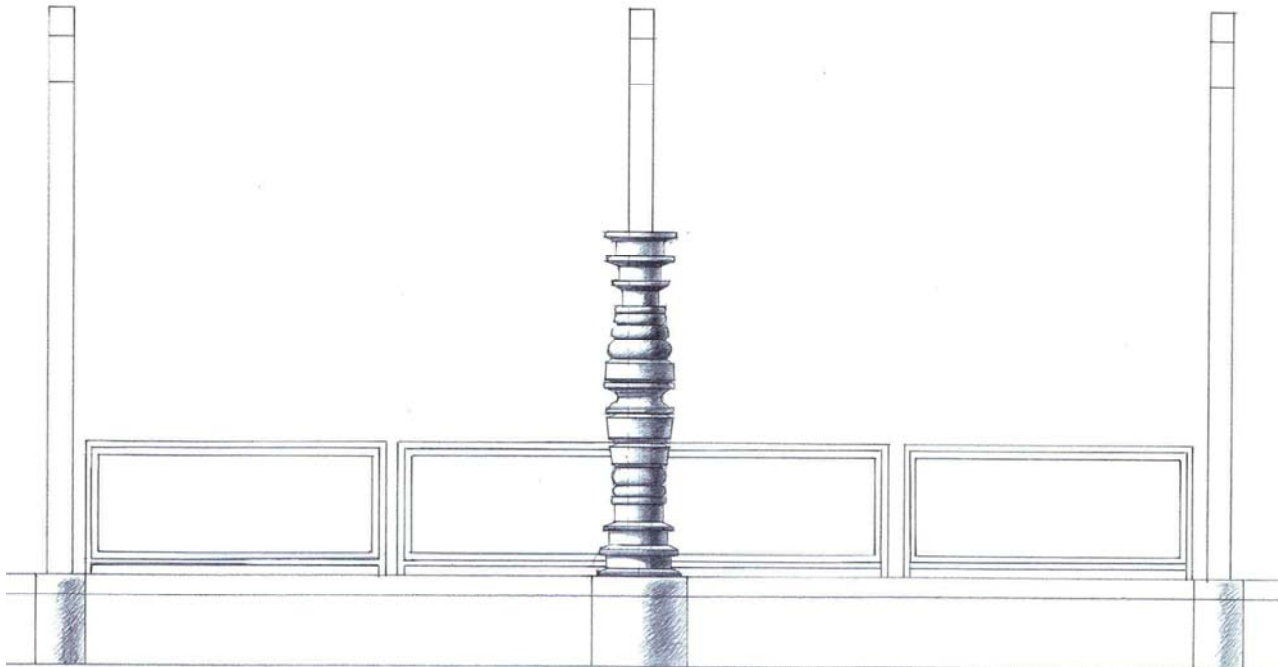

Bronze Stack of Wheels

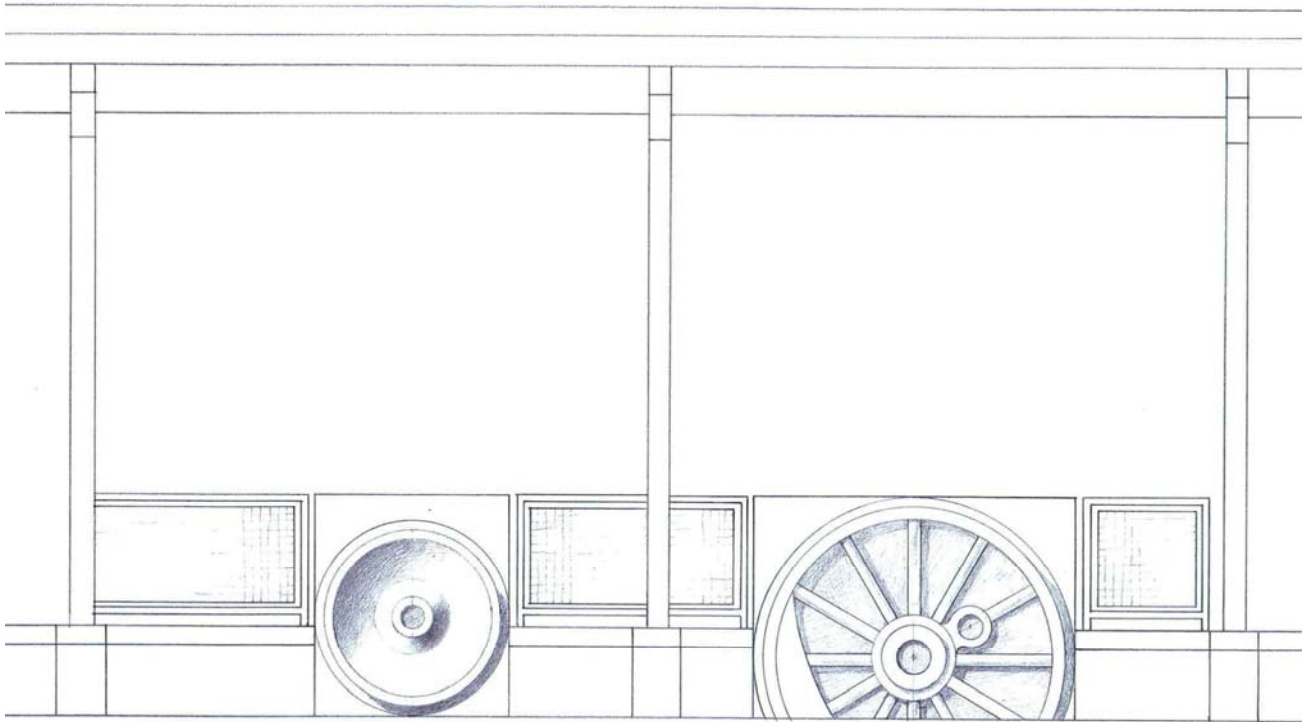

Black granite train wheels

About the project: The Central Corridor Light Rail Transit Project will link downtown St. Paul and downtown Minneapolis along Washington and University avenues via the State Capitol and the University of Minnesota. Construction would begin in 2010 on the planned 11-mile Central Corridor line, with service beginning in 2014. The line would connect with the Hiawatha LRT line at the Metrodome station in Minneapolis and the Northstar commuter rail line, which will begin operation in late 2009, at the new Minneapolis Multimodal Station. The Metropolitan Council will be the grantee of federal funds. The regional government agency is charged with building the line in partnership with the Minnesota Department of Transportation. The Central Corridor Management Committee, which includes the mayors of St. Paul and Minneapolis, the University of Minnesota and commissioners from Ramsey and Hennepin counties, provides advice and oversight. The Central Corridor LRT Project Website is www.centralcorridor.org.